

VN5XEH

Night Vision Outdoor Camera



Key Features of Effio-E

- 1/3" Sony 960H Ex-view HAD CCD II
- 650TVL(D)/ 700TVL(N)
- New Color Signal Processing for High Color Reproduction
- 2D DNR(Digital Noise Reduction)

Key Features of VN5XEH

- 15M IR Beam Distance
- 2.9mm/ 3.6mm/ 4.3mm/ 6mm/ 8mm Fixed Iris lens
- Digital Day & Night
- Intelligent IR Image Compensation
- Cable Managed Bracket
- IP67 Weatherproof
- 12VDC

Dimension

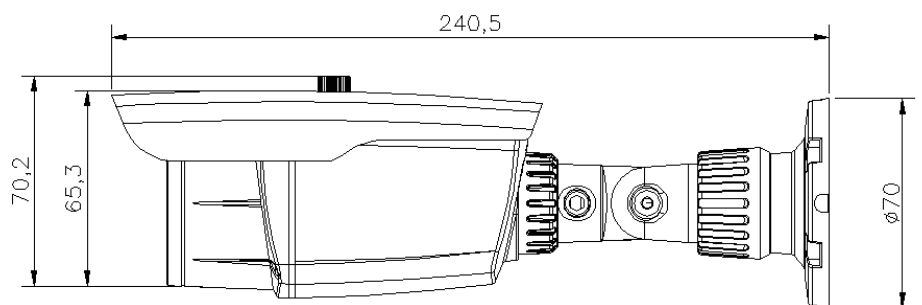
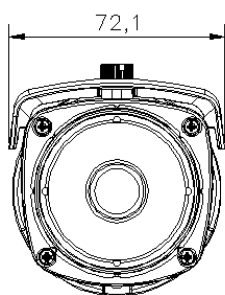

Specification

MODEL	VN5XEH
Image sensor	1/3" Sony 960H Ex-view HAD CCD II
Effective Pixels	NTSC : 976(H) x 494(V), PAL : 976(H) x 582(V)
H. Resolution	650TV Lines(Color)/ 700TV Lines(B/W)
Synchronizing system	Internal
Scanning system	NTSC : 525 Lines PAL : 625 Lines 2:1 Interlaced
Video output	1.0Vp-p Composite 75 Ohms
S/N ratio	More than 52dB (AGC Off)
Min. Illumination	0Lux
Shutter Speed	NTSC:1/60~1/100,000 sec. PAL:1/50~1/100,000 sec.
Gamma Correction	Standard $\gamma = 0.45$
White Balance	1,800 K ~ 10,500 K Auto
Gain Control	Standard : -6dB ~ 44.8dB Auto
Smear Effect	0.005%
Power source	12VDC
Operating current	100mA(IR Off), 250mA(IR On)
Lens	2.9mm/ 3.6mm/ 4.3mm/ 6mm/ 8mm Fixed Iris lens
LED Spectrum	850nm
Viewable Distance	Up to 15M at Moonless Night
MTBF of IR	20,000 hours
Iris Control	Electronic
Operating temp./Humidity	-10°C ~ 50°C (Humidity : 0% RH ~ 90% RH)
IP Rating	67
Measurement (mm)	72.1(W) x70.2(V)x240.5(L)
Weight (Approx. g)	490