

## VCQ-362DM



### Features

- ◆ 1/3" Panasonic 2.2M Progressive Scan CMOS
- ◆ SMPTE274M(1080@30p/25p, 720@60p/50p , 720p30/25)  
HD-SDI (270M , 1.485G , 2.97G)  
EX-SDI (Long Reach UP to300M (RG59))
- ◆ HD-SDI to EX-SDI Selectable by OSD
- ◆ f=3.6mm Fixed Lens  
Pinhole Lens(P4 4.3mm)
- ◆ Real-time WDR,2D/3D-DNR,ACE,HLM, Sens-up
- ◆ Built-in OSD Joystick

### Dimension

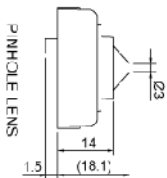
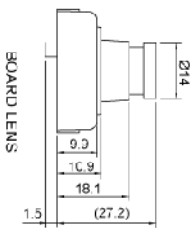
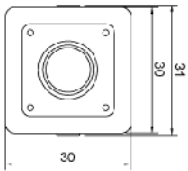

### Option



Lens

### Specification

Camera	Image Device	1/3 type Panasonic MOS
	Scanning System	Progressive Scan
	Total Pixels	1956(H) x1228(V) : 2.48Mega pixel
	Effective Pixels	1944(H) x 1092(V) : 2.12Mega pixel
	Lens fitted	Board, Pinhole
	Min. Illumination	0.1Lux@F1.4 , 30IRE
	Sync System	Internal
	Electronic Shutter	60Hz : 1/30~1/30,000sec, 50Hz : 1/25~1/30,000sec
Video	Output 1	HD-SDI (SMPTE 274M)
	Output 2(option)	CVBS (NTSC, PAL) without WDR
	Resolution& frame rate	1080@30p/25p, 720@60p/50p
OSD	On Screen Display	Built-in
	Language	English, Chinese, Chinese(S), Japanese
	LENS	DC/ MANUAL
	EXPOSURE	BRIGHTNESS/ SHUTTER MODE& SPEED/ SENS-UP
	WHITE BALANCE	AWB/ATW/ PUSH LOCK/ MANUAL
	WDR/ BLC/ ACE	OFF/ WDR/ BLC/ ACE
	DNR	OFF/ LOW/ MIDDLE/ HIGH
	DAY&NIGHT	AUTO/ EXT/ COLOR/ B&W
	IMAGE	SHARPNESS/ COLOR LEVEL/ MIRROR/ FLIP/ LENS SHADING/ GAMMA/ D-ZOOM/ DEFOG
	SPECIAL	COMM ADJUST/ PRIVACY/ HLC/ MOTION
	SYSTEM	FORMAT/ FPS/ FREQ/ CVBS SCALE/ CVBS OUT
	Others	Operating Temperature
Storage Temperature		-4°F~140°F (-20°C~~+60°C)
Humidity		Less than 80%
Power Consumption		DC12V(±10%), Max.130mA
Option		Lens

# VCQ-362DM

## Interface

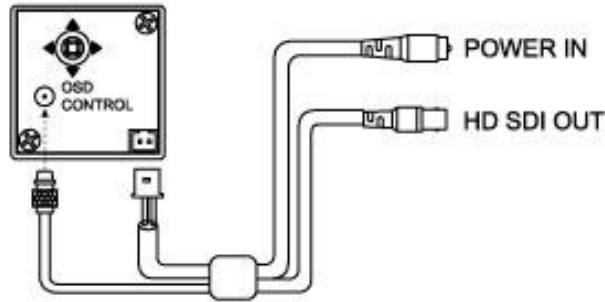

### DIY CABLE CONNECTION

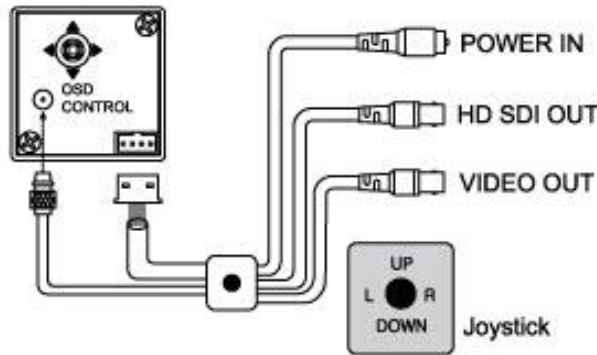

### OSD CABLE CONNECTION

