

VNE70S51X

2 Megapixel Full HD Vandal Dome IPCamera

Compact slim design with quick & easy installation



Key Features

- 2 Mega pixel 1/2.9" SONY progressive scan CMOS image sensor for excellent image quality
- 2.8mm Wide angle Megapixel Board Lens
(Option TBD : 3.6mm,6.0mm)
- Triple stream
- WDR, Defog, 2D/3DNR
- Supports image resolution up to 2MP
- 1920(H)x 1080(V) 2MP Max. 30fps
- Supports VBR/CBR in H.264
- Controllable frame rate
- Corridor view in H.264
- Tool-Free 3-Axis
- 12VDC/ IEEE802.3af POE
- Conformant with ONVIF (Profile-S)
- Includes Windows based IP Installer and license-free 16 channel NVR(Network Video Recorder) software

Dimensions

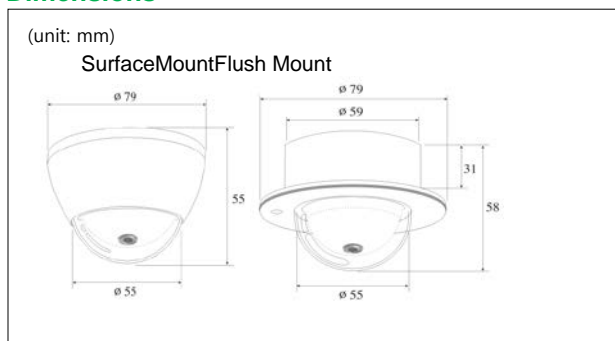

Specifications

MODEL	VNE70S51X
System	
CPU	ARM1176JZF-S (400 MHz, Instruction cache: 32kbyte, data cache)
Flash	2Gbit Flash memory
SDRAM	2Gbit DDR3 memory
Camera	
Image sensor	2.0 Megapixel 1/2.8" Progressive scan CMOS Image Sensor
Total Pixels	1952(H) x 1116(V) 2.18 Megapixel
Effective Pixels	1944(H) x 1104(V) 2.14 Megapixel
S/N Ratio	More than 50dB
Min. Illumination	0.2 Lux
Day & Night	Auto (AGC D/N)
Lens	2.8mm Megapixel Lens (Option TBD: 3.6mm, 6mm)
Video	
Video compression	H.264 High Profile@4.1, MJPEG-Image quality: 3 Steps
Resolutions	Up to 1920 x 1080 2MP
Frame rate	Triple Stream 1 st stream: 30fps@1920x1080 2 nd stream: 30fps@1280x720 3 rd stream: 30fps@640x480
Video streaming	Triple stream with H.264/MJPEG, Adjustable frame rate, CBR/VBR in H.264
Corridor view	Corridor view in H.264 (90degree/ 270degree)
Image Setting	Day & Night
	Auto White Balance
	Brightness, contrast, Sharpness
	Privacy Mask, Auto Exposure
	DSS, Effect - Color, Mirror/V-Flip, etc
Network/ System Integration	
Security	Password Protection, User access log, HTTPS encryption
Supported protocol	HTTP, HTTPS, FTP, SMTP, UPnP, DNS, DDNS, NTP, RTSP, RTP, TCP, UDP, ICMP, DHCP
Intelligent video	Object based Motion detection up with 12x 12 block Tamper detection with Global scene change and defocus
Alarm events	File upload via ftp, E-mail, Notification via email, SD Card.
Video buffer	5MB pre-alarm and 180 sec (max) post-alarm
Firmware upgrade	Remote upgrade via network
API	CGI Interface document, ActiveX Interface(ocx(dll) + document)
Physical	
Power Source	DC12V/1.5A,PoE(Power over Ethernet): 802.3af-Optional
Storage	Micro SD Slot (Built-in)
Power Consumption	Max. 3.3W
Net Weight	TBD
Dimension	Camera : Surface Mount : 79.0(Ø) x 55 (H) Flush Mount : 79.0(Ø) x 58 (H) IP decoding box : 66mm(W) x 31.5mm(H) x 107mm (D)
General	
Operating Temperature	-10 degree~50 degree Celsius(14F~122F)
Storage Temperature	-20 degree~60 degree Celsius(-4F~140F)
Software	
Included Software	NVR C/S (16 Channel), IP Installer (Windows only)

* Specifications are subject to change without prior notice.

Specialty Network

Dimensions (Unit :mm)

Main unit (Server)

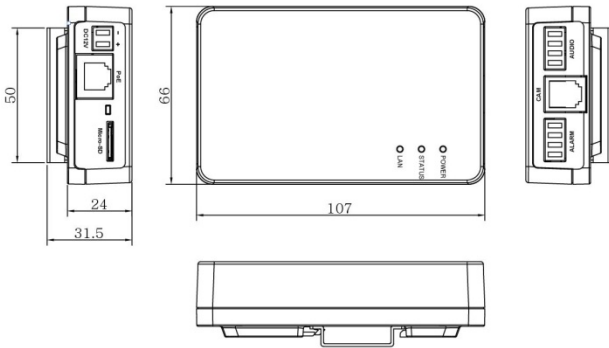

Functions

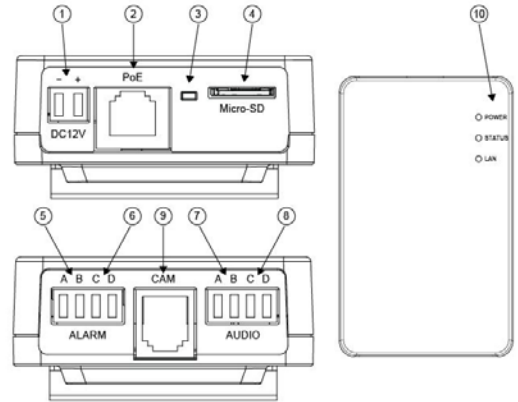

Installation (Hardware)

Main unit (Server)

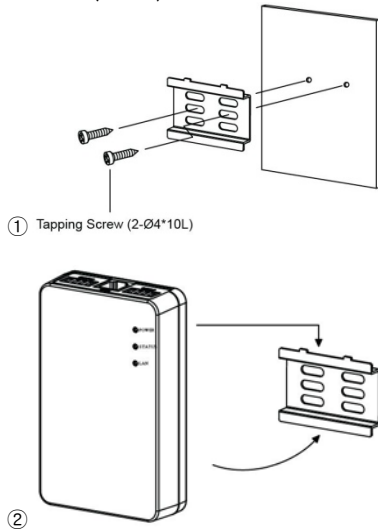

No.	Item	
①	Power connector (DC12V)	
②	Network and POE connector	
③	Reset button	
④	Micro SD card slot	
⑤	A	Alarm COM
	B	Alarm NO
	C	GND
⑥	C	GND
	D	Alarm IN
⑦	A	GND
	B	Micro phone
	C	GND
⑧	C	GND
	D	Line - Out
⑨	RJ-12 connector	
⑩	Power , Status , Link LED	